



Structural Analysis of the Multicircuit Link
Mechanism of the Bush Plant of Cotton
Pickering Device

Anvar Abdazimov and Shuhrat Siddikov

EasyChair preprints are intended for rapid dissemination of research results and are integrated with the rest of EasyChair.

April 2, 2020

Structural analysis of the multicircuit link mechanism of the bush plant of cotton pickering device

DSc., professor **A.D. Abdazimov**, senior teacher **Sh.Sh. Siddikov**
Tashkent state technical university named after Islam Karimov
(Tashkent, Uzb). Contact information (phone.; e-mail): +99890 9592796
anvarabdazimov95996@gmail.com

Abstract

Article is devoted to a research of the multicircuit slot mechanism for the plant of bushes vertically - the spindle harvest device of the mechanical cotton picker.

Research objective is carrying out the structural analysis of the multicircuit slot mechanism for the plant of bushes for identification of the reasons of its insufficient reliability and the development of optimum structure of the mechanism providing its sufficient reliability, durability and technological effectiveness.

The method of the structural analysis of a kinematic chain of the multicircuit slot mechanism determines quantities of the main mobile links and classes of kinematic couples, degree of freedom and the number of excess (six) communications of the mechanism. It is established that because of existence in a kinematic chain of excess communications, statically we will not define the mechanism. Taking into account possible errors of production and assembly flat multicircuit mechanisms can be considered as spatial. For definition of degree of freedom of a kinematic chain as spatial mechanism, Malyshev's formula which as the universal structural formula, allowed to estimate rationality of structure of the considered mechanism is used.

For elimination of excess communications in a kinematic chain of the mechanism, using a method of replacement of the lowest kinematic couples on the highest, the lowest kinematic couple a sliding bar with a crank with degree of freedom of $p_1=1$ (v) is replaced with the highest (a sphere in a cylinder) with degree of freedom of $p_4=4$ (B, B, B, o) therefore statically definable kinematic system is received.

The optimum structure of a kinematic chain of the multicircuit slot mechanism where degree of freedom of the mechanism it is equal to unit $W = 1$ is developed, that is the mechanism is set in motion by one propeller. Assembly of such mechanism happens without deformation of links are established and quite meet requirements of reliability, durability and technological effectiveness. In the course of work mechanisms without excess communications work without scratch and noise.

Key word: cotton picker, mechanism, structure, kinematic couple, multicircuit, crank, sliding member.

Introduction. At the Tashkent state technical university (TSTU) the mechanical cotton picker (MCP) with the spindle drums equipped with the multicircuit link mechanism for the plant of bushes (MPB) in the working chamber [1.2] which at cross-validation state testing vertically spindle KHOUM proved the advantage on agro technical indicators on increased by 50% of operating speed of rather serial machines was developed.

Multicircuit link MPB represents the crank and link mechanism (fig. 1) having three main mobile links placed in a serial spindle drum. Mobile links of the mechanism – mechanism of governing plants for working camera (round rods) - the rotating and shaking scenes, in the course of work supporting sliding bar on a spindle drum in a input part of the working chamber influences fruit branches and boxes of a cotton, directing them to opposite spindles. Thereby earlier is provided and is longer than in serial, engagement of spindles with cotton boxes, i.e. favorable conditions for process of collecting by cotton-raw spindles at the increased machine speeds are created.

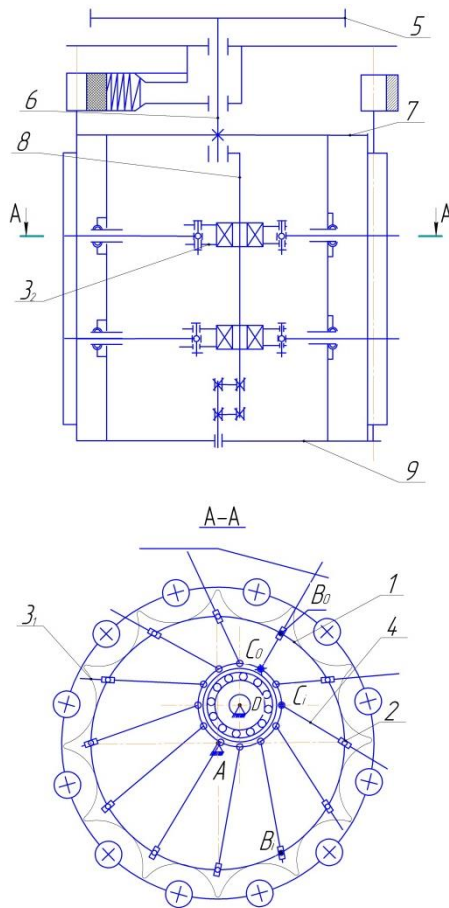

Fig. 1. A schematic circuit of a spindle drum with multicircuit link MPB. 4-sliding member

1 cogwheels, the 2nd shaft an axis of the rotating scenes, a 3-upper disk, 4 cylinder (crank), a 5-sliding member (the shaking stone, a 6-round rod of the rotating coulisse, the 7-cartridge rotating the scenes, the 8-shaking coulisse, 9- axis of carriages, 10 – the lower disk.

Use of MPB on hinged KHOUM of HNP-1.8A with the increased operating speed KHOUM for 50%, according to state tests in the Uzbek machine testing station [3], allowed to bring completeness of harvesting in the machine bunker on the first collecting to 88.5%, and for double collecting up to 92.5%. Semi-hinged MX-1.8 KHOUM the equipped MPB by results of cross-validation testing KHOUM in the State center of tests and certification of the new equipment and technologies of the Republic of Uzbekistan in a season showed to cleaning of cotton-raw of 2014 completeness of collecting on the first collecting 85.13%, against serial 79.61%. At double collecting the second collecting was made at once after the first collecting, the machine equipped with MPB collected in the bunker 93.99%, at 90.7% at compared serial [4].

At the same time introduction to construction of a spindle drum of multicircuit link MPB considerably complicated it, increased metal consumption and an energy consumption. It and also tolerances and assemblies led to decrease in constructive reliability - during tests there were failures in the form of breakdowns and bends of separate details of the mechanism, such as round rod of the rotating coulisse, failure of weld joints of balsas to a cylinder, bends of rods of the shaking scenes.

Analyzing causes of failures, came to a conclusion about need carrying out in-depth studies of structure of MPB for development of its optimum structure as multicircuit link mechanism.

Object and methods. In a kinematic chain of a spindle drum with multicircuit link MPB, the movement (torsional moment) from a cogwheel 5 (see fig. 1) 6 is transmitted through a shaft to an upper disk 7.

To flanges upper 7 and the lower disk 9, the cylinder 1, which transfers a torsional moment to the lower disk and working links of the multicircuit link mechanism, is welded. The crank (cylinder) transfers a torsional moment to a round rod of the rotating coulisse 3₁ by means of a sliding bar (the swinging stone) 2. Round rod 3₁ is rigidly connected to cartridge 3₂. To the cartridge of the rotating coulisse in turn eleven shaking scenes 4 pivotally are connected. The shaking scenes are set in motion on the one hand from a crank by means of sliding bar in a point of *Bi* and from the cartridge of the rotating coulisse in a point of a swivel joint of *Ci*. At the same time, rotation of the cartridge of the rotating coulisse depends on rotation of a crank on some pattern.

Such mechanisms two are installed in the spindle reel - the upper cartridge - at the height of 400 ... 450 mm and the lower cartridge - at the height of 200 ... 250 mm from the lower disk of a spindle drum. Let's make structural analysis of multicircuit MPB.

Each mechanism consists of three main mobile links (a crank, a sliding bar and the rotating coulisse) and eleven shaking scenes which are pivotally connected to the rotating coulisse in a point of C_i and to a crank by means of sliding bar in B_i point, and make planimetric (repeated) communications. We can carry these units because of identity in a form of construction and the principle of the movement, on two groups - sliding bar of 11 pieces, and the shaking scenes of 11 pieces.

It is well-known that the mechanical engineering cannot be represented without link mechanisms. Many famous authors [5-12] considered and studied link mechanisms in many manuals. And investigated by many leading scientists in the field of the theory of mechanisms of machines [13-24]. Link mechanisms in these works are investigated.

For achievement of the specified purpose we use a technique of structural analysis of a kinematic chain of the mechanism.

For defining of freedom degree of kinematic flails of the multicircuit link mechanism, we will analyze kinematic couples of the main links of the mechanism.

1 link - a cylinder of a spindle drum - the entrance link is a link to which the movement transformed by the mechanism to required movements of other links is reported. It rotates around axis O (see fig. 3, a) on 360° , is called - a crank [6];

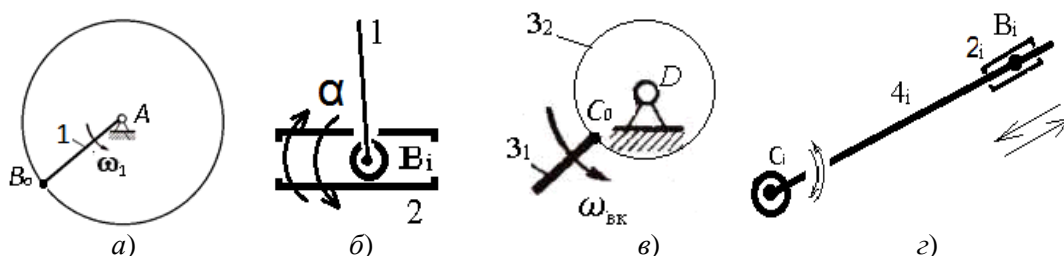

Fig. 2. A schematic circuit of multicircuit link MZK for a spindle drum

1 crank (cylinder); a 2-sliding member (the swinging stone); A 3₁-round rod of the rotating coulisse; 3₂- the cartridge of the rotating coulisse; 4-shaking coulisse (a round rod)

2 - the **sliding member** - turns on some limited coal around the vertical axis of fastening to a crank (cylinder) in B_i point (see fig. 3, b);

3 - the link - **the rotating coulisse**, consists of two rigidly connected

details: 3₁ - the round rod has reciprocating motion concerning a sliding member in B_3 point, and is rigidly connected to the cartridge in C_0 point; 3₂ - the cartridge - it is pivotally connected to a rack on axis D and rotates around this axis on 360° (see fig. 3, c);

Round rod 3₁ is connected to cartridge 3₂ rigidly, points of their relative positioning do not change therefore we will consider them as a link consisting of two rigidly connected details. As the round rod has reciprocating motion concerning a sliding member to B_0 point, and the cartridge rotates around axis D on 360° , we will call it the **rotating crank arm**.

4 link - other all 1₁ round rods as they have reciprocating motion concerning a sliding member in B_i point (see fig. 3, d), and with the cartridge have a swivel joint in a point of C_i which allows to turn on limited угол-α (see fig. 3, d), we will call them - the shaking scenes.

For structural analysis we will consider communications of kinematic couples separately. According to the theory of mechanisms of machines on any kinematic couple from two firm links having movable connections are imposed from one to five conditions of communication - S , on relative the movement of these links [6]. And the number of degrees of freedom of a link of a kinematic couple - N is defined from expression:

$$H=6-S \quad (1)$$

In a spindle drum as was it is stated above, such mechanisms it is set two and they are identical on construction, with one general initial link - a crank (1 link). As the crank with a rack is the general initial link for both cartridges, quantity of the main mobile links (without additional planimetric links) on the second cartridge two ($n=2$), a sliding member and the rotating coulisse

The first kinematic couple consists of two details: a motionless axis of spindle reel *A* and pivotally the crank (cylinder) connected to it (see fig. 2, a) which has only rotational motion around this axis. As, the first link – an axis of a spindle drum in a point *And* - we will accept its motionless, it treats a rack, and the cylinder has only rotational motion around axis *A* on 360°; it treats a **crank**. Possible movements are imposed by the 5th on the others communication conditions. We define degree of freedom for a kinematic couple from expression (1):

$$H=6-S=6-5=1$$

The second kinematic couple a **sliding member** (a link stone) concerning a **crank** has an opportunity to turn on a limited corner *ui* on a vertical axis of the fastening in *Bi* point (see fig. 2, b), possible movements are imposed by the 5th on the others communication conditions. We define degree of freedom of a kinematic couple from expression (1): $N = 6-S=6-5=1$

Kinematic couple - ***pI*** (c) one-mobile, rotary. As, on a spindle drum two cartridges of the mechanism at the different levels on height, such kinematic couples too two ***pI*** (c) =2 piece are installed.

The third kinematic couple - **the rotating crank** – a sliding bar. The round rod of the rotating coulisse, concerning a sliding bar has reciprocating the movement in *Bi* point (see fig. 2 v), possible movements are imposed by the 5th on the others communication conditions. We define degree of freedom of a kinematic couple from expression (1):

$$H=6-S=6-5=1$$

Kinematic couple – ***pI*** (p) one-mobile, progressive, such kinematic couples on a spindle drum also two *rI* (o) =2 piece.

We define degree of freedom of a kinematic chain of the main links of the mechanism, consisting of five mobile links: a crank (fig. 2 a) of-1 piece, a sliding bar (fig. 2 b). And also the rotating crank (fig. 2 v) (without 11 pieces of the shaking scenes and 11 pieces of sliding bar), number of mobile links of $n=5$ and number of kinematic couples with one degree of freedom $r_I=4$.

We determine degree of freedom of a kinematic chain of the mechanism for the flat mechanism by P.L. Chebyshev's formula [6-8]:

$$W = 3n - 2p_H - p_B \quad (2)$$

where: n – number of the main mobile links of a kinematic chain, $n=3$

p_H - number of kinematic couples of the lowest class (a kinematic couple with degree of freedom of $H=1$,

$p_H=4$ pieces;

p_B - number of kinematic couples of the top class (a kinematic couple with degrees of freedom $H=2$,

$p_B = 0$ pieces.

From expression (2) we have:

$$W = 3n - 2p_H - p_B = 3 \cdot 5 - 2 \cdot 7 - 0 = 1$$

It means that this mechanism has one initial link or one generalized coordinate.

In the analysis of the mechanism with optimum structure consider that the rack considered as a rigid motionless link in actual practice under the influence of applied loads deformations are exposed. In the deformed status they can have impacts on relative provisions of elements not only within one kinematic couple, but also within the closed kinematic chain of the mechanism. At the wrong choice of the structure, diagram jammings (jamming) of some elements of a kinematic couple, emergence of considerable additional loadings because of a distortion, a bend, stretching of links, excessive wear of elements of a kinematic couple are in use possible what to lead to increase in an energy consumption of the mechanism, low reliability, frequent failures of construction.

Taking into account possible tolerances and assembly flat mechanisms can be considered as space as it is noted in [6] (above we considered the mechanism in the plane). In this regard, for definition we determine degree of freedom of a kinematic chain of space mechanisms by Malyshev's formula which becomes the universal structural formula allowing to estimate rationality of structure of the considered mechanism.

$$W = 6n - (5p_1 + 4p_2 + 3p_3 + 2p_4 + p_5 - q)$$

or

$$W = 6 \cdot n - \sum_{i=1}^5 (6 - i) \cdot p_i + q \quad (3)$$

where: 6 – the number showing that at the space movement each link has six degrees of freedom; 5, 4, 3, 2 and 1 – the number of the communications imposed on relative movements of links corresponding one - two - three - etc. to mobile kinematic couples; p_1, p_2, \dots, p_5 – respectively quantity and a look one - two - three - four - and five mobile kinematic couples.

In a formula (3) degree of mobility of a kinematic chain of the mechanism (W) is for geometrical reasons the known value equal to the number of generalized coordinates, i.e. quantity of an initial link (initial links) with the set law of the movement, in it only the number of excess communications - q is subject to definition

$$q = W - 6n + \sum_{i=1}^5 (6 - i)p_i \quad (4)$$

q – total number of excess (repeated) communications, which duplicate other communications, can enter the total number of the imposed communications, without reducing mobility of the mechanism, only turning it into statically indefinable system [6]. In number the number of excess communications (q) is equal to the number of the sizes demanding exact execution. With accounting of excess communications, freedom degree for the space mechanism we can will determine by Malyshev's formula:

$$W = 6n - (5p_1 + 4p_2 + 3p_3 + 2p_4 + p_5 - q) = 6 \cdot 5 - 5 \cdot 7 + q = q - 5$$

Excess communications for the considered mechanism where $W=1$, we define from expression (4):

$$q = W - 6 \cdot n + (5 \cdot p_1 + 4 \cdot p_2 + 3 \cdot p_3 + 2 \cdot p_4 + p_5) = 1 - 6 \cdot 5 + 5 \cdot 7 = 6$$

It means that in this mechanism three sizes demand exact execution. Such sizes are movement on Oy axes and turns on axes of Ox and Oz of the closing kinematic couple. For normal functioning of this mechanism, it is necessary to carry out axes of all rotary kinematic couples parallel, without distortion concerning the plane of the movement of kinematic links, which also should be not warped (i.e. not bent).

At design of the structural diagram of the mechanism, without excess planimetric communications, should provide conditions of assembly of the closed kinematic chains (circuits) of the mechanism. It is the kinematic chain forming the closed circuit (or mechanism circuits, should gather without tightness even in the presence of deviations of the sizes of links and deviations of arrangement of a surface and axes of elements of a kinematic couple. Aim to develop such skeleton diagram, which would eliminate possibility of additional loadings in a kinematic couple due to configuration change of a circuit of links irrespective of the accuracy of production of details or deformability of a rack and other links [6] for real mechanisms.

If there are no excess communications, i.e. $q = 0$, then assembly of the mechanism happens without deformation of links. Self-installed links, which are established and quite meet requirements of reliability, durability and technological effectiveness. Mechanisms without excess communications work at practice without scratch and noise. The mechanism without excess communications has optimum structure and is called self-established [7] by Reshetov's definition. If excess communications are, i.e. $q > 0$, then assembly of the mechanism and the movement of its links are possible only at their deformation. Signs of existence in the mechanism of excess communications it is a scratch, squeal and noise during the operation of such mechanisms.

In the main engine the kinematic chain has 3 excess communications. $q > 0$ – it means this kinematic system statically of a indeterminate. To bring it into statistically definable kinematic system it is necessary that q equaled to zero. For achievement of it is necessary will replace one of the lowest kinematic couples with the highest kinematic couple, with degree of freedom of $H=4$.

For this purpose a kinematic couple of a sliding member with a crank – the lowest a kinematic couple with degree of freedom it is replaceable on the highest (a sphere in a cylinder) a kinematic couple with degree of freedom of $p_4=1$ (v, v, v, o) therefore we will receive a kinematic system statistically definable.

The kinematic couple a sliding member concerning a crank has an opportunity to turn on a limited corner on an axis of the fastening in Bi point (see fig. 4, b), with degree of freedom of $p_1=1$ (v). The point of Bi belongs to three links of the mechanism at once: to a crank-1, polzushke-2 and the rotating coulisse-3. We can replace a swivel joint of a sliding member with a crank (see fig. 4, b), on a sphere in a cylinder. Then we will receive a space kinematic couple with freedom degree: 3-rotary on coordinate axes of XYZ ,

and on limited forward $p_4=1$ in a cylinder (v, v, v, o), communication conditions are imposed on other 2 possible movements.

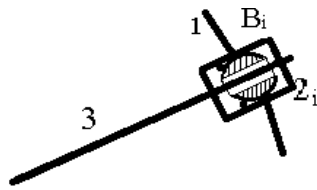

Fig.3. The scheme of a kinematic couple of a sliding member with a crank a sphere in a cylinder with $p_4=4$ (v, v, v, o),

Now we will define degree of freedom of a kinematic couple from expression (1)

$$H=6-S=6-2=4$$

The kinematic couple a crank – a sliding bar (a sphere in a cylinder) has 4 degrees of mobility r_4 (3v, p) and such kinematic couples of 2 pieces, on one for each cartridge.

Taking into account the made changes we define excess communications in the kinematic scheme of the main mobile links of the mechanism

$$q=W-6 \cdot n+5 \cdot p_1+4 \cdot p_2+3p_3+2p_4+p_5=1-6 \cdot 5+5 \cdot 5+2 \cdot 2=0$$

Now a kinematic chain of the mechanism is statically an definable.

Results and discussion. As it was stated above in the mechanism except the main links there are still in addition 22 shaking scenes and 22 sliding bar, with kinematic couples which are necessary for technological efficiency of the multicircuit link mechanism and belong to planimetric communication. Then, without planimetric communications if to analyze a vertical spindle drum with two cartridges that we will receive:

The structural diagram the mechanism in original form:

- the main mobile ringing $n_{och}=3+2=5$ pieces.

Kinematic couples of the fifth class $p_1=7$ pieces:

- a ranc A - crank $p_1=1$ pieces;

A ranc D – rotating crank $p_1=1 \cdot 2=2$ pieces;

- a crank – sliding member $p_1=1 \cdot 2=2$ pieces;

- rotating crank of sliding bar $p_1=1 \cdot 2=2$ pieces;

kinematic couple of the second class p_4 :

crank – sliding bar $p_4=0$ piece.

Kinematic couples of the fifth class r_1 :

After a solution of objectives, with conversion of kinematic couples, the structural diagram of the considered multicircuit link mechanism is provided to optimum structure and has the following indicators specified in tab. 1.

Table 1. Comparative data of results of structural analysis of multicircuit link MPB

parameters involved	mechanisms involved	On considered mechanism	On the mechanism with optimum structure
Input link		1	1
Number of the main mobile links, n (piece)		4	4
Kinematic couples (piece)		7	7
Kinematic couples of the fifth class p_1 (piece)		7	5
Kinematic couples of the second class p_4 (piece)		0	2
Kinematic couples of the first class p_5 (piece)		0	0
Degree of freedom of a kinematic		5	1

chain, W		
Excess communications of q (piece)	6	0

Conclusion. By results of the conducted researches in a kinematic chain of multicircuit link MZK of a spindle drum, excess communications are eliminated. Kinematic chain of the mechanism statically definable. Such mechanisms without excess planimetric communications are called self-established or optimum, rational structure [7]. Such skeleton diagram gathers without tightness even at deviations of the sizes of links and deviations of arrangement of surfaces and axes of elements a kinematic couple, eliminates possible emergence of additional loadings in a kinematic couple due to configuration change of a circuit of links irrespective of the accuracy of production of details or deformability column and other links. Elimination of excess communications provides high reliability, decrease in wear of details, increase in useful effect of the machine, decrease in operating costs [6].

In the developed structure of a kinematic chain of the mechanism has degree of freedom $W=1$, i.e. the entrance link of the mechanism is set in motion by one engine.

References

1. А.С. №1664162 (СССР) “Хлопкоуборочный аппарат” / А.С.Садридинов и др., Б.И.1991г. №27.
2. Патент РУз. №2474, “Хлопкоуборочный аппарат с пальцевым механизмом” / А.С.Садридинов и др., Расмий ахборотнома, 1995г, №2.
3. АКТ Уз МИС №50-92 (539) государственных испытаний машины ХНП -1,8 с механизмом завода кустов. -Янгиюль Уз МИС,1992.
4. Результаты испытаний хлопкоуборочных машин в сезоне уборки хлопка-сырца 2014 года. - Гультяхор: УзГЦИТТ, 2014 г.
5. Артоблевский И.И. Теория механизмов и машин, М.: Наука, 1975.- 639 с.
6. Фролов К.В., Попов С.А. и др., Теория механизмов и машин, М.: Высшая школа, 1987.- 496с.
7. Решетов Л.Н., «Самоустанавливающие механизмы», Справочник, М.: Наука, 1979г.
8. Юдин В.А., Петрокас Л.В. Теория механизмов и машин, М.: Высшая школа, 1977г.
9. Бутенин Н.В. Курс теоретической механики / Н.В. Бутенин, А.Я. Лунц, Д.Р. Меркин. – СПб.: Лань, 1998. -736 с.
10. Бугаенко Г.А. Основы классической механики / Г.А. Бугаенко, В.В. Маланин, В.И. Яковлев. – М.: Высшая школа, 1999. – 366 с.
11. Кожевников С.Н. Механизмы. Справочное пособие / С.Н. Кожевников, Я.И. Есипенко, Я.М. Раскин // Под редакцией С.Н. Кожевникова.–М.: Машиностроение, 1976. – 784 с.
12. Крайнев А.Ф. Словарь-справочник по механизмам / А. Ф. Крайнев. – М.: Машиностроение, 1987. – 560 с.
13. Туранов Х.Т. Проектирование кривошипно-ползунных механизмов в вычислительной среде MathCAD: Учебн. пос. / Х.Т. Туранов, А.Н. Бондаренко. – Новосибирск: Изд-во СГУПС (НИИЖТа), 2000. 132 с.
14. S.M.Targ. A Potted Course of Theoretical Mechanics: Manual for Technical Universities. (Moscow). (1998).
15. Hasan A. Study of Multiple Jointed kinematic chains // International Journal of Computational Engineering Research. 2018. No.1. Vol. 8. – P. 13 – 19.
16. Лазарян В.М. Обобщенные функций в задачах механики / В.А. Лазарян, С.И. Конашенко. – Днепропетровск: ДИИТ, 2004. 187 с.
17. Туранов Х.Т. Анализ траектории движения характерных точек планетарных механизмов / Х.Т. Туранов, Н.Н. Бегимов // Теория механизмов и машин. 2019. №4. Том 16. –С.139-149.
18. Agrawal V.P. and Rao J.S. (1987). The Mobility Properties of Kinematic Chains. Mech. Mach. Theory. 22: 497-504.
19. Chu Jin-Kui and Cao Wei-Qing. (1994).Identification of Isomorphism among Kinematic Chains and Inversions Using Link’s Adjacent-Chain-Table. Mech. Mach. Theory. 29:53 – 58.
20. Advanced Theory of Mechanisms and Machines / [М. Kolovsky, A. Evgrafov, Yu. Semenov, A. Slousch]. – Berlin: Springer, 2000. – 396 p.
21. Uicker J.J., Pennock G.R. Theory of Mechanisms / J. J. Uicker, G. R. Pennock. – New York: Oxford Univ. Press, 2003. – 928 p.
22. Rao a.b.s., Srinath A. and Rao A.C. (2006).Synthesis of Planar Kinematic Chains. Institution of Engineers (I). 86: 195-201.

23. Rizvi S.S.H., Hasan A., Khan R.A. (2016). A New for distinct inversions and isomorphism detection in kinematic chains. *Int. J. Mechanisms and Robotic Systems*, Inderscience Enterprises Ltd .3: 1, 48-59.
24. Pozhbelko V.I., Kuts E. Structural synthesis of planer 10-link–DOF kinematic chains with up to pentagonal links with all possible multiple joint assortments for mechanisms deign // *New Advances in Mechanism and Machine Science*. Mechanism and Machine Science. Vol.57. Switzerland: Springer, 2018. – P. 27 – 35.