



Management for the Operators Activity in the  
Polyergatic System. Method of Functions  
Distribution on the Basis of the Reliability  
Model of System States

---

Evgeniy Lavrov, Nadiia Pasko and Valentyna Borovyk

EasyChair preprints are intended for rapid  
dissemination of research results and are  
integrated with the rest of EasyChair.

January 6, 2021

# Management for the Operators Activity in the Polyergatic System. Method of Functions Distribution on the Basis of the Reliability Model of System States

Evgeniy Lavrov  
Department of Computer Sciences  
Sumy State University  
Sumy, Ukraine  
prof\_lavrov@hotmail.com

Nadiia Pasko  
Department of Cybernetics and Informatics  
Sumy National Agrarian University  
Sumy, Ukraine  
senabor64@ukr.net

Valentyna Borovyk  
Department of Computer Sciences  
Sumy State University  
Sumy, Ukraine  
bvalena56@ukr.net

**Abstract**— The article shows the relevance of the tasks of the human factor in polyergatic system. The authors suggest a mathematical formulation of the optimization problem in the distribution of functions between the operators subject to resource constraints, technological and ergonomic requirements. The article demonstrates the capabilities of the computer implementation models.

**Keywords**— *polyergatic system; algorithm of activity; human operator; operator-leader; ergonomics; distribution of functions; optimization; decision support*

## I. INTRODUCTION

A From 50% to 80% of accidents in different types of manufacturing systems, more than 64% of accidents in the Navy and 80% in the aviation caused by the human-operator error. Researches in the field of human-machine systems (HMS) design aimed to reduce human-operator error reactions, to ensure acceptable conditions of the operator work and to adapt the "machine part" to the human [1-8]. The effectiveness of ergonomic researches greatly depends from the ability to formalize the interaction between human and machine, and to receive operative estimation of activity organization variants, to solve the optimization tasks.

The last years are characterized by rapid change in the nature of automated control technologies:

- prevalence of distributed control systems with random input time of requests;
- growth in the number of operators-technicians working in a single information space (in complex systems at various levels, ranging from a few people to a few dozen people);
- increased requirements for operative decision-making;

- hierarchical management has resulted in increased roles and responsibilities of operators-supervisors – those who make decisions, including secure of operators-technicians for requests;
- a need for keeping records of working conditions in the workplace of the operators has increased;
- a variety of options has increased:
  - in function (embedding) implementation techniques;
  - in ways to perform certain operations;
  - in securing operators for requests (operations);
- increased cost of errors.

## II. LITERATURE REVIEW AND PROBLEM STATEMENT

The main tasks of ergonomics are [3,9-11]:

- Selection of the degree of automation (distribution of functions between the person and the machine);
- Distribution of functions between operators;
- Designing information models for the human operator;
- Designing of activity algorithms for human operator;
- Professional selection of operators;
- Designing working conditions at operator workplaces.

The solution of all these problems is necessary in order to [1,2,12-14]:

- Reduce the number of errors;

- Increase the timeliness of problem solving;
- Reduce the burden on the human body of the operator and reduce the risks of disease.

The number of information systems, in which many (several dozen or several hundred) operators works simultaneously was increased in recent years [9,11,13]. Such systems are called polyergatic [3]. People-operators are often engaged in different tasks (applications) processing [1,2]. At the same time, new applications can be received in random times) [1,2,6,9]. It is necessary to appoint these applications for specific operators quickly. At the same time, high reliability of application processing should be ensured, as well as high timeliness [1,2,14-17]. A special class of "operators-managers" or "operators-leaders" has appeared. Such operators are managers for "operators-executors" [3]. The operator-manager works on the basis of intuition often [1,2,16,17]. But such methods of work do not provide the required quality [3,17]. The task of distribution of functions should be solved on the basis of an assessment of the reliability of the activity [3]. The possibility of obtaining such estimates may appear if we use models based on the apparatus of functional networks to describe the activity of operators [3,14,15]. However, it is almost impossible to evaluate quickly all possible options for the operator-leader [16,17]. Therefore, the problem of supporting decision-making based on solving the optimization task arises [1,17,18].

Thus, it is necessary to develop a formal model for the class of problems related to the decision to organize the implementation of operational input of (one) query, based on the need for a comprehensive account of:

- ergonomic standards and requirements;
- technological limitations.

We start from the fact that the operator-leader, based on the current state of the system at some point in time, given the employment of operators, their individual characteristics, level of training, the opportunity to work together, working conditions in the workplace, must choose the destination operators for phased process implementation of the received query.

To make decisions about consolidating functions is, as a rule, to ensure maximum efficiency of the system, or else, to cause minimal damage from the effects of different types of errors on the stipulation that the following restrictions are provided:

- technological;
- ergonomic;
- compatibility of elements;
- certain time of sale;
- cost resource consumption.

The mathematical model of the optimization problem of the request execution accuracy and the mathematical model of the problem of minimizing the damage from the effects of different type errors in the general case is defined in [16]. Posed problem in a general way, depending on many factors, generates a plurality of local optimization problems that must be solved in each particular case. Based

on the analysis of the general statement and the prevailing conditions on the content of the decision that must be made, we can distinguish the following main types of optimization problems (excerpt):

- A general view of the optimization problem for a variety of functional structures (ways of doing) and the number of all operators;
- Optimization of one embodiment of the functional structure and a set of operators for each operation of the algorithm of activity;
- Optimization of one embodiment of the functional structure and one operator per one operation of the algorithm of activity;
- Optimization of one embodiment of the functional structure and one operator for the entire algorithm of activity.

Some decisions of problems, arising in practice, were developed in [17-21]. Many models are described in general terms or are applicable for particular cases. Optimization on the functional network (graph of works) [3,14-15] can only be applied to sequential type algorithms. Therefore, in order to solve the problem, in the general case, a transition from the graph of works to some other model of the description of the functioning algorithm is necessary. As such a model, a model of the reliability of states of a polyergatic system can be proposed.

The purpose of this article is

- to develop an optimization model of the problem of distributing functions between operators for the reliability model of states of a polyergatic system (event graph);
- to test the model's operability.

### III. RESULTS

#### A. Reliability Model of States for a Polyergatic System

The primary and more natural form of representation of the functioning algorithms is the work graph. However, such a model does not allow optimization for algorithms with feedback. Therefore, we propose to construct an additional model that describes the states of the polyergatic system. We are interested in the states associated with the absence or presence of errors in the activities of operators. We will neglect with the possibility of a structural failure of the system.

To obtain the event graph, each vertex of the work graph must be associated with events corresponding to the beginning or end of the corresponding work or operation. The outcomes of work can be several, in the simplest case, two: erroneous execution and error-free execution. Each of the outcomes is associated with a separate arc on the graph. Each of the following states corresponds to different outcomes of the functioning algorithms, in the simplest case: correct and incorrect.

As a result, we obtain a probability oriented graph  $G(X, Z)$ , where  $X$  is a set of vertices, and  $Z$  is the set of arcs. An example of the transition from the works graph to the event graph is shown in Fig. 1

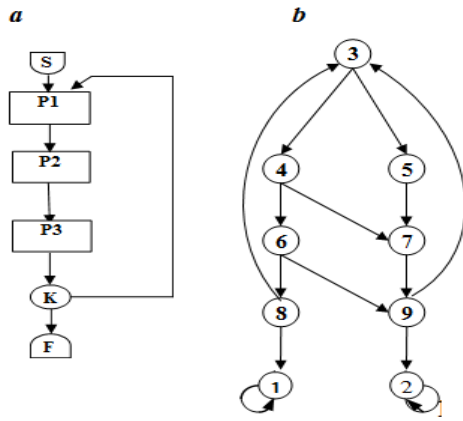

Fig. 1. An example of a transition from a work graph to an event graph: *a* – a work graph; *b* – an event graph; **P1**, **P2**, **P3** – working operations, **K** – control operation; **S** – starter, **F** – finisher (notation – according to [3]). 1 and 2 are absorbing states: 1- completion of activity without error; 2- completion of activities with an error.

There are distinguished initial and final states on the graph of the works. Among the final states (absorbing peaks numbered by the first  $r$  positive integers), there are isolated states corresponding to implementation of the algorithm without the error (positive outcomes  $r_1$ ). In order to optimize complex algorithms, there should be provided the absorption of the process to a given vertex.

### B. The Approach to Posing the Problem of Functions Distribution Using the Reliability Model of Polyergatic System's States

Thus, it is necessary to provide the maximum probability of hitting the vertex, which corresponds to an error-free function's execution.

In this case, the alternatives are the operators who can be entrusted with the execution of the function (in this article we consider the case when individual (not group) activity is expedient).

In this case, the model of the optimization problem is:

$$P_r = \sum_{l=1}^N \sum_{i=r+1}^N \sum_{k \in K_i} P_{il}^{(k)} x_i^{(k)} \rightarrow \max P_r \quad (1)$$

$$\sum_{k \in K_j} x_j^{(k)} - \sum_{i=r+1}^N \sum_{k \in K_i} P_{ij}^{(k)} x_i^{(k)} = a_j, \quad j = r+1, r+2, \dots, N \quad (2)$$

$$\sum_{k \in K_i} \delta_i^{(k)} = 1, \quad \text{at all } i \quad (3)$$

$$\delta_l^{(k)} = \delta_m^{(k)} = \dots = \delta_i^{(k)}, \quad \text{at all } k \in K_i \quad (4)$$

$$x_i^{(k)} - M\delta_i^{(k)} \leq 0, \quad \text{at all } i \text{ and all } k \in K_i \quad (5)$$

$$x_i^{(k)} - m\delta_i^{(k)} \geq 0, \quad \text{at all } i \text{ and all } k \in K_i \quad (6)$$

$$\sum_{j=1}^r \sum_{i=r+1}^N \sum_{k \in K_i} P_{ij}^{(k)} x_i^{(k)} = 1, \quad (7)$$

$$x_i^{(k)} \geq 0 \quad \text{at all } i \text{ and all } k \in K_i \quad (8)$$

where:  $K$  is a set of operators of the system;

$N$  is total number of vertices, the first  $r$  of which are absorbing;

$P_r$  is probability of absorption in the  $r$  state (or states of the  $r$ -type);

$P_{ij}(k)$  is probability of transition of the system from vertex  $i$  to vertex  $j$  when choosing the  $k$ -th decision;

$a = (a_{r+1}, a_{r+2}, \dots, a_N)$  is vector of initial probabilities, at that:

$$\sum_{i=r+1}^N a_i = 1;$$

$K_i$  is a set of alternatives or solutions that can be applied to the vertex of the graph of events  $K_i \in K$ ;

$m$  and  $M$  are sufficiently small and sufficiently large numbers.

The meaning of these constraint is the following:

1) The constraint (3) for a boolean variable  $\delta_i^{(k)}$  requires that for each  $i$ , only one  $\delta_i^{(k)}$  is equal to one;

2) The constraint (4) requires that solutions for dependent states coincide;

3) The constraint (5) requires that for each  $i$  at the most one  $x_i^{(k)}$  is nonzero (together with constraint (8));

4) The constraint (6) requires that for each  $i$  one or more  $x_i^{(k)}$  are nonzero. Constraints (5) and (6) taken together require that only one  $x_i^{(k)}$  is different from zero;

5) The constraint (7) is a normalized condition, that requires the process to be absorbed with probability 1.

The solution of the problem (1) - (8) has the property that for each  $i$  the only one  $x_i^{(k)}$  and one  $\delta_i^{(k)}$  are non-zero. This means that to perform operation in the vertex  $i$ , the  $k$ -th decision is taken ( $k$ -th operator is assigned). Constraint (4) ensures  $k$ -th decision-making based on the dependent vertices (the whole algorithm of activities performed by one operator).

### C. An Example of Solving the Problem of Distributing Functions Between Operators on the Reliability Model of States of a Polyergatic system

The algorithm is modeled operator activity typical functional structure "Working operation - control of functioning". The graph of works shown in Figure 2 (a), and the graph of events - in Figure 2 (b). The function is fastened after one of four operators.

It is necessary to decide the task of choice of operator at presence of dependent operations. Matrix of transition probabilities of implementation operations each of the four operators are shown in (Figure 3).

Elements of this matrix are the transition probabilities from each current state (by rows) to each subsequent state

(by columns). Obviously, such probabilities depend on the characteristics of the operator (preparedness, motivation, functional state, etc.). Therefore, a special matrix is formed for each operator. It characterizes the reliability characteristics of this operator.

Vector of initial probabilities:  $a = (a_3, a_4, a_5) = (1, 0, 0)$ . An objective function and system of limitations answers formulas (1)-(8).

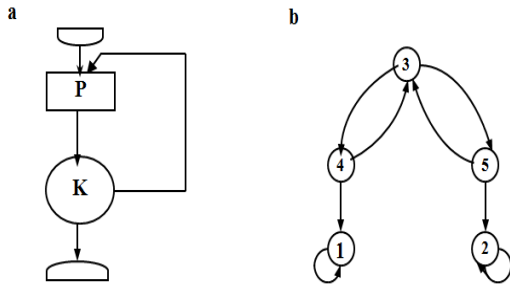

Fig. 2. Typical functional structure "Working - control operation." Earl works (a), Count of events (b).

The problem of optimizing the choice of the operator:

$$P_l = \sum_{i=3,4} \sum_{k=1}^4 P_{il}^k * x_i^k \rightarrow \max$$

$$\sum_{k=1}^4 x_3^{(k)} - \sum_{i=4,5} \sum_{k=1}^4 x_i^{(k)} * P_{i3}^{(k)} = 1$$

$$\sum_{k=1}^4 x_4^{(k)} - \sum_{i=3,5} \sum_{k=1}^4 x_i^{(k)} * P_{i4}^{(k)} = 0$$

$$\sum_{k=1}^4 x_5^{(k)} - \sum_{i=3,4} \sum_{k=1}^4 x_i^{(k)} * P_{i5}^{(k)} = 0$$

$$\sum_{k=1}^4 (x_4^{(k)} * P_{41}^{(k)} + x_5^{(k)} * P_{52}^{(k)}) = 1$$

$$\sum_{k=1}^4 \delta_i^{(k)} = 1, \text{ at } i = 3,4,5$$

$$\delta_3^{(k)} = \delta_4^{(k)} = \delta_5^{(k)}, \text{ at } k = 1,2,3,4$$

$$x_i^{(k)} - M\delta_i^{(k)} \leq 0, \text{ at } i = 3,4,5 \text{ and } k = 1,2,3,4$$

$$x_i^{(k)} - m\delta_i^{(k)} \geq 0, \text{ at } i = 3,4,5 \text{ and } k = 1,2,3,4$$

$$x_i^{(k)} \geq 0, \delta_i^{(k)} \in \{0,1\}, \text{ at } k = 1,2,3,4$$

As a result we get the value of objective function and value of variables:  $P_l=0,999588$ ;  $x_3^{(3)}=1,0303>0$ ;  $x_4^{(3)}=1,0200>0$ ;  $x_5^{(3)}=0,0103>0$  (Figure 4).

It is seen (from this figure) that it is necessary to choose the solution with the number 3 (high index) for all vertices of the graph. This applies to  $x$  and  $\delta$  variables. The number of this solution corresponds to the number of the operator

that will ensure the maximum error-free solution of the problem. As can be seen, the predicted probability of error-free execution with this decision will be 0.999588.

1st operator, matrix $[P_{ij}^{(1)}]$				
1	0	0	0	0
0	1	0	0	0
0	0	0	0,91	0,09
0,92	0	0,08	0	0
0	0,05	0,95	0	0
2nd operator, matrix $[P_{ij}^{(2)}]$				
1	0	0	0	0
0	1	0	0	0
0	0	0	0,9	0,1
0,93	0	0,07	0	0
0	0,03	0,97	0	0
3rd operator, matrix $[P_{ij}^{(3)}]$				
1	0	0	0	0
0	1	0	0	0
0	0	0	0,99	0,01
0,98	0	0,02	0	0
0	0,06	0,94	0	0
4th operator, matrix $[P_{ij}^{(4)}]$				
1	0	0	0	0
0	1	0	0	0
0	0	0	0,93	0,07
0,935	0	0,065	0	0
0	0,05	0,95	0	0

Fig. 3. Matrix of transition probabilities

The conclusion from the analysis of the result of the solution of the problem (Figure 4). The values obtained for the objective function and variables indicate that a maximum probability of error-free operation of the algorithm is achieved, when the function performs a third operator.

#### D. The Novelty of the Model.

The novelty is that:

- unlike empirical methods of distribution of functions between operators, a method is proposed that uses objective quantitative indicators;
- reliability model of system states was first used for the task of distributing functions between operators of a polyergic system.

#### IV. IMPLEMENTATION

The developed model was used in the development of a computer system for decision-making support for operators-leaders.

This system was tested in the operation of control systems of various technological processes.

Among them:

- gas pipeline management system,
- system for calculating payments for utilities,
- a banking management system,
- a system for managing access to distributed information resources and services.

In addition, the model was used in the preparation of masters in the disciplines "Ergonomics" and "Information Systems" in:

- Sumy State University;
- Sumy National Agrarian University;
- Ukrainian Engineering and Pedagogical Academy (Kharkov).

## V. FUTURE WORK

It is necessary to develop the following models:

- multicriteria distribution of functions;
- a model that takes into account the preferences of the operator-leader and operators-executors.
- expert system on operators' preferential capabilities

## VI. CONCLUSIONS

1. A problem situation of making a decision concerning the assignment of operators-technologists of polyergatic computer systems raises many optimization problems that can be efficiently solved by using formalisms of functional networks.

2. The novelty of the approach is the use of quantitative indicators for making decisions about the distribution of

functions and the rejection of intuitive methods. Optimization models of the distribution of functions between the operators are an integral part of the ergonomic support system of the polyergatic computer systems.

3. It is convenient to solve the problem if we first describe the functioning in the form of the reliability model of the polyergatic system's states, those, in addition to the graph of works, construct a graph of events.

4. The problem is reduced to the problem of maximizing the probability of process absorption at the vertex, which corresponds to the error-free execution of functioning algorithm.

5. The convenience of the approach is that the problem is reduced to the problem of linear programming.

7. The application of the model makes it possible to find ergonomic reserves for increasing the reliability of polyergatic systems.

8. The restriction is the need to have initial data on the reliability of all operators.

9. Implementation recommendations - using the model as an element of a decision support system for the operator-leader. Optimization models of the distribution of functions between the operators must become an integral part of the ergonomic support system of the polyergatic computer systems.

Variables												
Variable Name	$X_3^1$	$X_3^2$	$X_3^3$	$X_3^4$	$X_4^1$	$X_4^2$	$X_4^3$	$X_4^4$	$X_5^1$	$X_5^2$	$X_5^3$	$X_5^4$
Value	0,0000	0,0000	1,0303	0,0000	0,0000	0,0000	1,0200	0,0000	0,0000	0,0000	0,0103	0,0000
Lower limit	0	0	0	0	0	0	0	0	0	0	0	0
Integer variables												
Variable Name	$\delta_3^1$	$\delta_3^2$	$\delta_3^3$	$\delta_3^4$	$\delta_4^1$	$\delta_4^2$	$\delta_4^3$	$\delta_4^4$	$\delta_5^1$	$\delta_5^2$	$\delta_5^3$	$\delta_5^4$
Value	0	0	1	0	0	0	1	0	0	0	1	0
Upper limit	1	1	1	1	1	1	1	1	1	1	1	1
Integer	integer	integer	integer	integer	integer	integer	integer	integer	integer	integer	integer	integer
	i=3	i=4	i=5									Route
Probability of finding of the system in the initial state in the peak of I	1	0	0	The objective function:	$X_3^{(1)+P_{31}^{(1)}+X_3^{(2)+P_{31}^{(2)}+X_3^{(3)+P_{31}^{(3)}+X_3^{(4)+P_{31}^{(4)}}+X_4^{(1)+P_{41}^{(1)}+X_4^{(2)+P_{41}^{(2)}+X_4^{(3)+P_{41}^{(3)}+X_4^{(4)+P_{41}^{(4)}} \rightarrow \max$						0,999588	Maximum

Fig. 4. Results of decision of task (MS Excel, excerpt)

## REFERENCES

- [1] P. C. Cacciabue. "Human error risk management for engineering systems: a methodology for design, safety assessment, accident investigation and training." *Reliability Engineering & System Safety*, vol. 83, issue 2, pp. 229–269, 2014. DOI: 10.1016/j.res.2003.09.013
- [2] M. Havlikovaa, M. Jirglb and Z. Bradac. "Human reliability in man-machine systems," *Procedia Engineering*, vol. 100, pp. 1207–1214, 2015. DOI:10.1016/j.proeng.2015.01.485
- [3] A. N. Adamenko, A. T. Asherov, I. L. Berdnikov et al. *Informacionno-upravljajushhie cheloveko-mashinnye sistemy: Issledovanie, proektirovanie, ispytaniya. Spravochnik [Information controlling human-machine systems: research, design, testing. Reference book]*, A.I. Gubinsky & V.G. Evgrafov, eds. Moscow, Russia: Mashinostroenie, 1993. (In Russian).
- [4] C. F. Sergeev, P. I. Paderno and A. N. Anokhin. "International scientific conference "Psychology of labour, engineering psychology and ergonomics-2014." *Psikhologicheskii zhurnal*, vol. 36(2), pp. 128-131, 2015.
- [5] A. S. Sergeeva and S. F. Sergeev. "Psihologija na grani tehnologicheskij singularnosti [Psychology on the brink of technological singularity]." *Psikhologicheskii Zhurnal*, vol. 38, issue 3, pp. 124–128, 2017. (In Russian), DOI: 10.7868/S0205959217030114
- [6] S. F. Sergeev, A.N. Anokhin, P. I. Paderno and A.A. Oboznov. "II International scientific-practical conference "Ergo 2016: Human factor in complex technical systems and environments." *Psikhologicheskii Zhurnal*, vol. 38, issue 1, pp. 136–138, 2017.
- [7] N. A. Sedova, V. A. Sedov and R. I. Bazhenov. "Analysis of emergency level at sea using fuzzy logic approaches," in *Proceedings of the International Conference of Artificial Intelligence, Medical Engineering, Education, AIMEE 2017*,

- Advances in Intelligent Systems and Computing*, 2017, pp. 314–322, DOI: [https://doi.org/10.1007/978-3-319-67349-3\\_30](https://doi.org/10.1007/978-3-319-67349-3_30)
- [8] V. A. Sedov, N. A. Sedova and S. V. Glushkov. "The fuzzy model of ships collision risk rating in a heavy traffic zone." *Vibroengineering PROCEDIA*, vol. 8, pp. 453–458, 2016.
- [9] J. Davy et al. "The BRICS<sub>plus</sub> Network: a historical overview and future perspectives of the network's role in human factors and ergonomics," in *Proceedings of the 20th Congress of the International Ergonomics Association (IEA 2018)*, IEA 2018, *Advances in Intelligent Systems and Computing*, 2018, pp. 647–656. DOI:10.1007/978-3-319-96080-7\_78
- [10] C. Osterman et al. "Conceptual and practical strategy work to promote ergonomics/human factors in Sweden," in *Proceedings of the 20th Congress of the International Ergonomics Association (IEA 2018)*, IEA 2018, *Advances in Intelligent Systems and Computing*, 2018, pp. 320–329. DOI: 10.1007/978-3-319-96080-7\_37
- [11] N. A. Nazarenko, P. I. Paderno and I. G. Gorodetsky. "Training of ergonomists (preparation and retraining)," in *Proceedings of the Third International Conference Ergo-2018: Human Factors in Complex Technical Systems and Environments (Ergo-2018)*, 2018, pp. 77–81. DOI:10.1109/ERGO.2018.8443911
- [12] V. S. Martina and S. F. Sergeev. "Engineering and psychological problems of multidimensional interfaces," in *Proceedings of the Third International Conference Ergo-2018: Human Factors in Complex Technical Systems and Environments (Ergo-2018)*, 2018, pp. 94–96. DOI:10.1109/ERGO.2018.8443865
- [13] A. V. Bogomolov, G. A. Sviridyuk, A. V. Keller, V. N. Zinkin and M. D. Alekhin. "Information-logical modeling of information collection and processing at the evaluation of the functional reliability of the aviation ergate control system operator," in *Proceedings of the Third International Conference Ergo-2018: Human Factors in Complex Technical Systems and Environments (Ergo-2018)*, 2018, pp. 106–110. DOI: 10.1109/ERGO.2018.8443849
- [14] M. G. Grif, E. V. Geniatulina and N. D. Ganelina. "Design and modelling in optimization of human-machine systems functioning," in *Proceedings of the International Siberian conference on control and communications (SIBCON-2015)*, 2015, p.5. DOI: 10.1109/SIBCON.2015.7147025
- [15] M. G. Grif, S. A. Kocheto and N. D. Ganelina. "Functional-structural theory based techniques for human-machine systems optimal design," in *Proceedings of the 13 International Scientific Technical Conference on Actual Problems of Electronic Instrument Engineering (APEIE)*, 2016, pp. 494–497.
- [16] E. Lavrov, O. Kuppenko, T. Lavryk and N. Barchenko. "Organizational approach to the ergonomic examination of E-learning modules." *Informatics in Education - an International Journal*, vol.12, issue. 1, pp. 107–124, 2013.
- [17] E. Lavrov, N. Pasko, A. Tolbatov and V. Tolbatov. "Ergonomic reserves for improving reliability of data processing in distributed banking systems," in *Proceedings of 2<sup>nd</sup> International Conference on Advanced Information and Communication Technologies-2017 (AICT-2017)*, 2017, pp. 79–82.
- [18] E. Lavrov, N. Barchenko, N. Pasko and A. Tolbatov. "Development of adaptation technologies to man-operator in distributed E-learning systems," in *Proceedings of 2<sup>nd</sup> International Conference on Advanced Information and Communication Technologies-2017 (AICT-2017)*, 2017, pp. 88–91.
- [19] E. Lavrov, N. Barchenko, N. Pasko and I. Borozenec. "Development of models for the formalized description of modular e-learning systems for the problems on providing ergonomic quality of humancomputer interaction." *Eastern-European Journal of Enterprise Technologies. Ser. "Information technology"*, vol. 2/2 (86), pp. 4–13, 2017. DOI: 10.15587/1729-4061.2017.97718
- [20] E. Lavrov, N. Pasko, A. Tolbatov and V. Tolbatov. "Cybersecurity of distributed information systems. The minimization of damage caused by errors of operators during group activity," in *Proceedings of 2<sup>nd</sup> International Conference on Advanced Information and Communication Technologies-2017 (AICT-2017)*, 2017, pp. 83–87.
- [21] E. Lavrov, N. Pasko, A. Kryvodub and A. Tolbatov. "Mathematical models for the distribution of functions between the operators of the computer-integrated flexible manufacturing systems," in *Proceedings of the XIIIth International Scientific Conference TCSET'2016*, 2016, pp. 72–75.